

LifeFitness

ARCTIC SILVER 90T-XXXX-05 TREADMILL

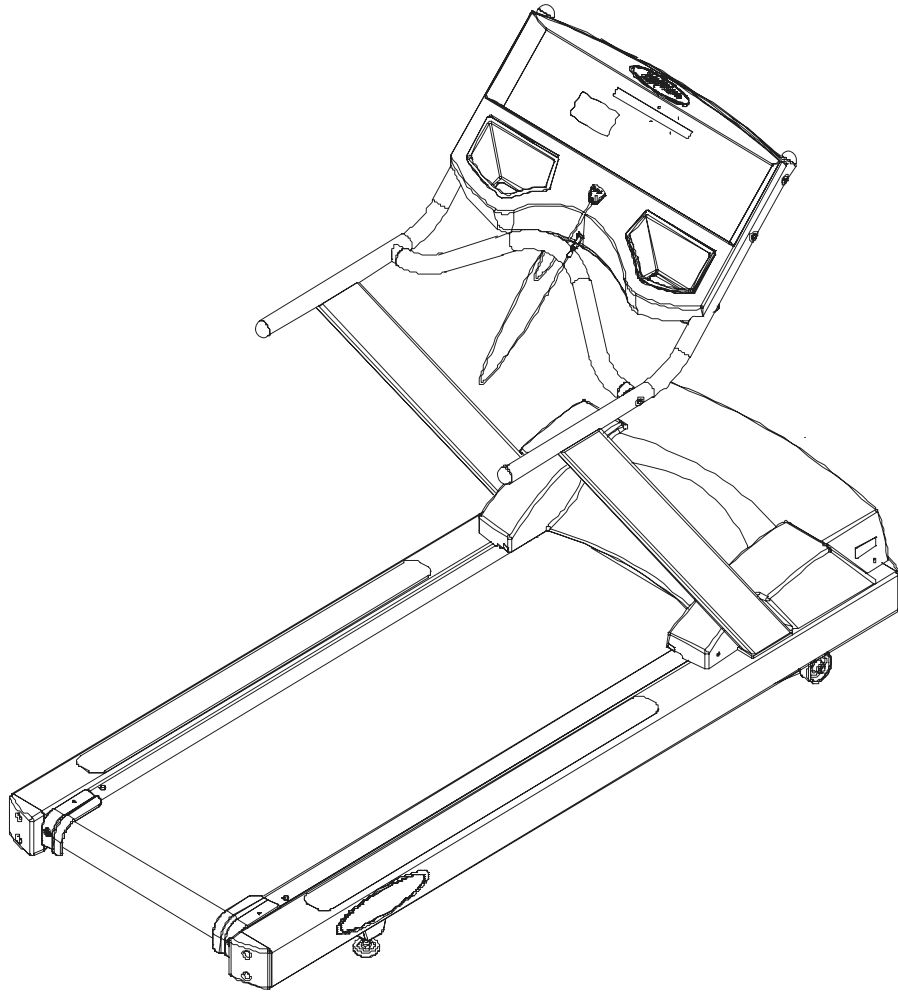

Customer Support Services
PARTS MANUAL rev 06 Aug 2012

Miscellaneous	3
Console Assembly	4
Motor Cover, Leveler, and End Caps	7
Ergo Bar and Upright Assembly	8
Accessory Trays.....	9
Belt, Deck, and Rollers	10
LifeSprings and Anti-static Tinsel.....	11
Lift Frame Assembly	12
Lift Motor and Home Switch.....	13
Drive Motor Assembly.....	14
Wax Motor, Wax Bag, Wax Nozzle, and Bracket	15
Speed Sensor and Sensor Wheel Assembly	16
Rear Roller Guards	17
DC Controller and On/Off Switch.....	18
Line Cord and Line Filter.....	19
Cables.....	20

Language	Operation Manuals*	Assembly Instructions*	Instruction Bag Assembly	Service Manual
English	M051-00K60-A079	M051-00K60-A083	N/A	M051-00K60-A023
French	M051-00K60-A080	M051-00K60-A084	N/A	
Portuguese				
Spanish				
Dutch	M051-00K60-A081	M051-00K60-A085	N/A	
German				
Italian				
Japanese	N/A	N/A	N/A	

*If available, operation manuals and assembly instructions are available only in PDF form

AK60-00161-0000 HDWR-BAG ASSY: MFG; 90TW BM		
Item	Description	Qty
OK60-01098-0001	END-CAP: SPHERE	4
0017-00021-2846	CONN FTYPE PNL F01S RD GP F B	1
0017-00042-1151	RIVET: PLASTIC; REMOVABLE	5
0017-00101-1256	3/8 -16X80 UNS HEX BLT G5 ZN B	4
0017-00101-1767	1/4 -20X28 TRX BUT L CS G8 ZS B	4
0017-00101-1768	1/4 -20X32 TRX BUT L CS G8 ZS B	2
0017-00101-1776	VMI 10-16X 8 PHL PAN B ST ZB B	10
0017-00103-0188	NUT 3/8 -16 LOCK-FLNGE D ST CD B	4
0017-00104-0464	WSH 406-.734-064 FL-D ST ZS B	4

Touch-up Paint		
Item	Description	Qty
0017-00008-0204	PAINT: CAN; SPRAY; ARCTIC SILVER B	1
0017-00008-0205	PAINT: BOTTLE; ARCTIC SILVER B	1
0017-00008-0206	PAINT: STEALTH GREY; .6OZ. BTL. B	1

Pre-Wired Cables for LCD Bolt-On		
Item	Description	Qty
AK32-00020-0002	CBL-ASSY: COAX; 120 IN. S/C-B	1
AK32-00078-0001	CBL-ASSY: PWR EXT; 120" S/C-C	1

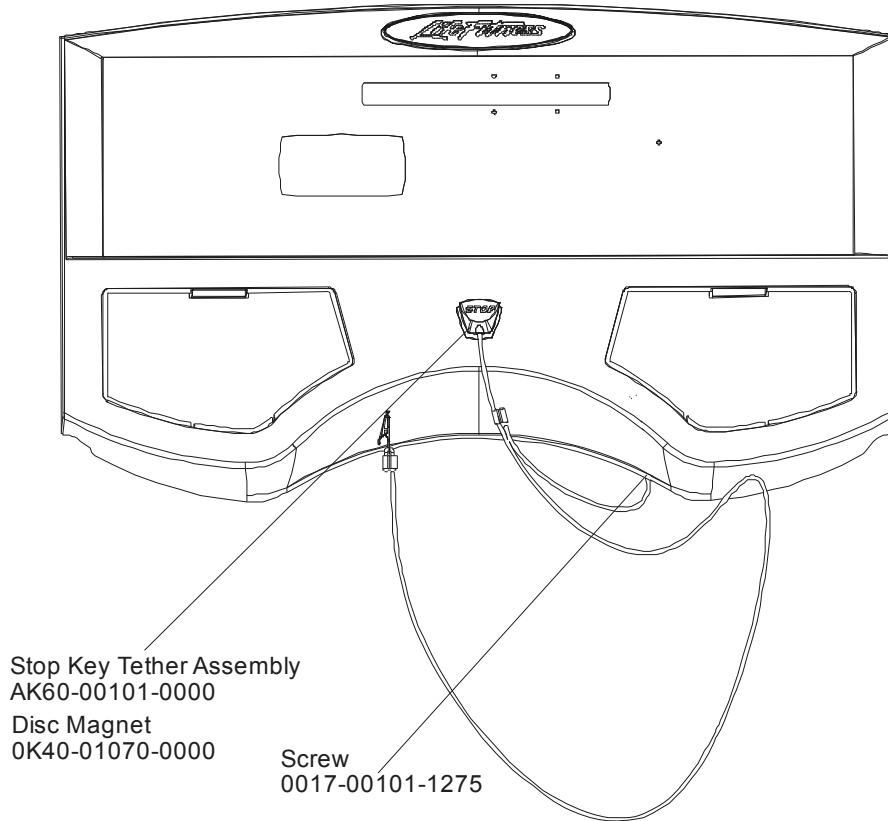

Language	Console	Overlay/Bezel Assembly
Eng+Met	AK60-00214-0001	AK60-00213-0001
German	AK60-00214-0003	AK60-00213-0003
Spanish	AK60-00214-0004	AK60-00213-0004
Japanese	AK60-00214-0006	AK60-00213-0006
French	AK60-00214-0007	AK60-00213-0007
Italian	AK60-00214-0008	AK60-00213-0008
Dutch	AK60-00214-0009	AK60-00213-0009
Portuguese	AK60-00214-0010	AK60-00213-0010

*Some consoles and overlay/bezel assemblies may be unavailable

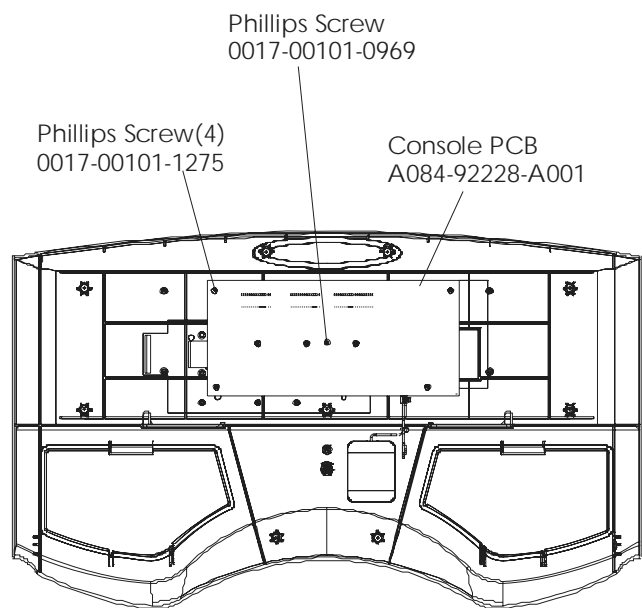
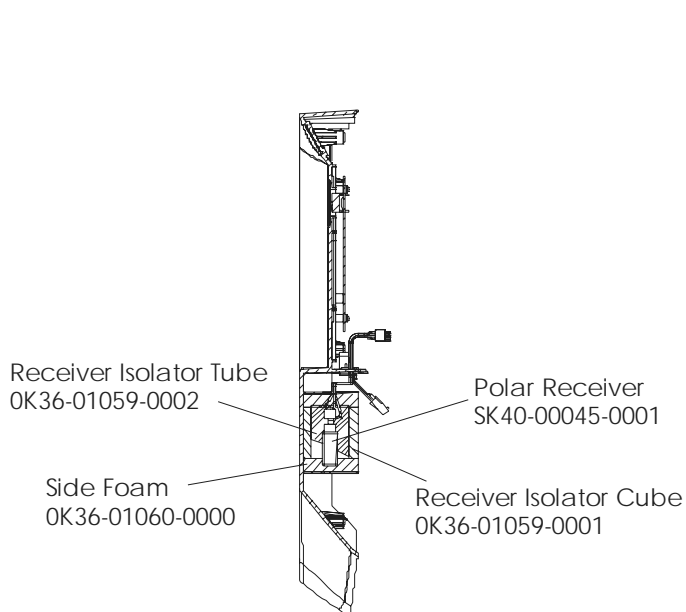
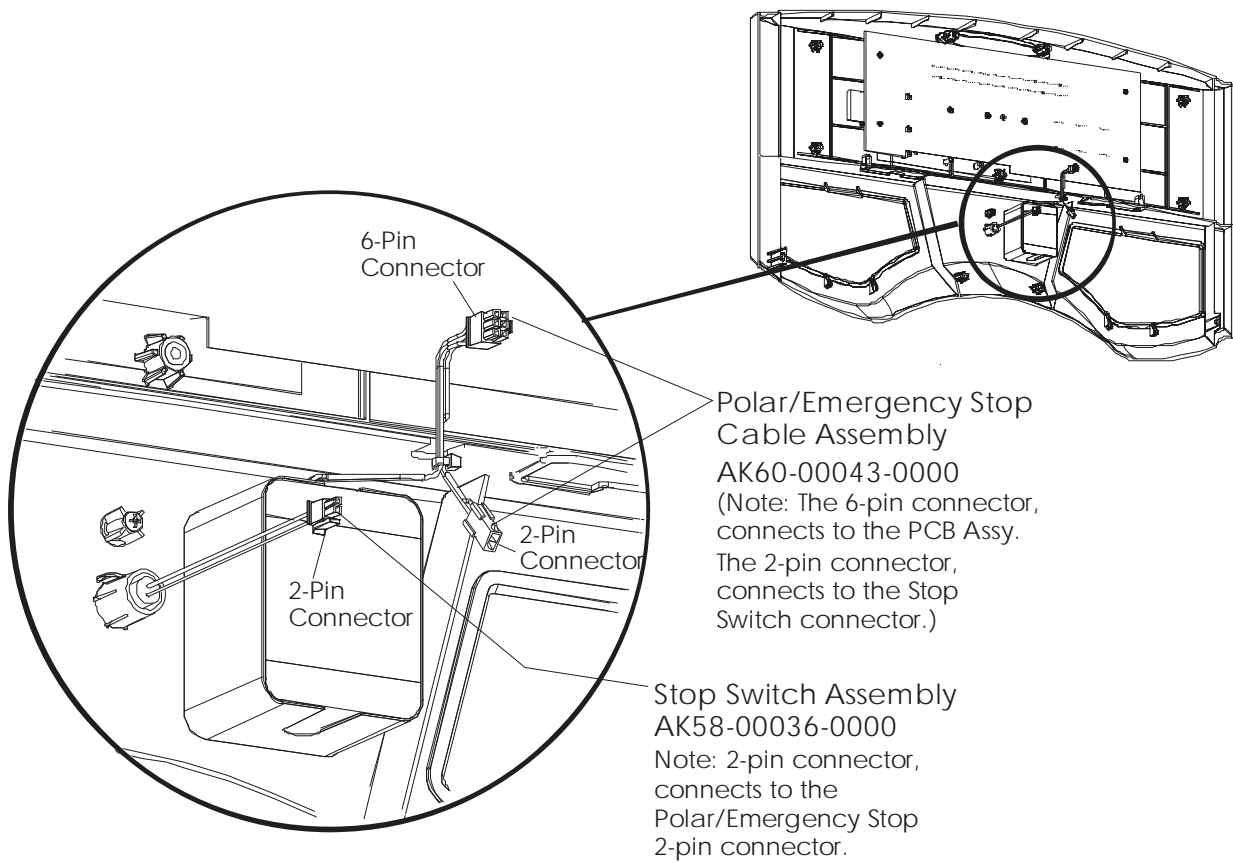

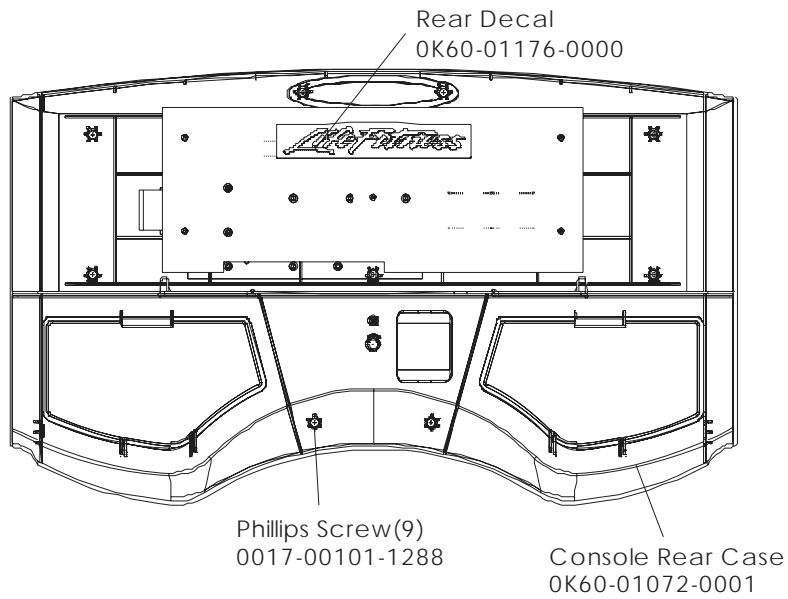
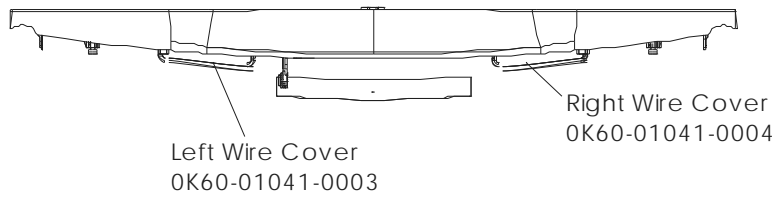
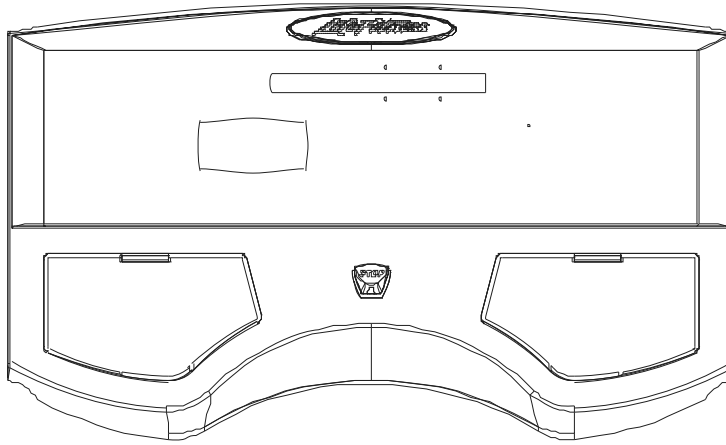

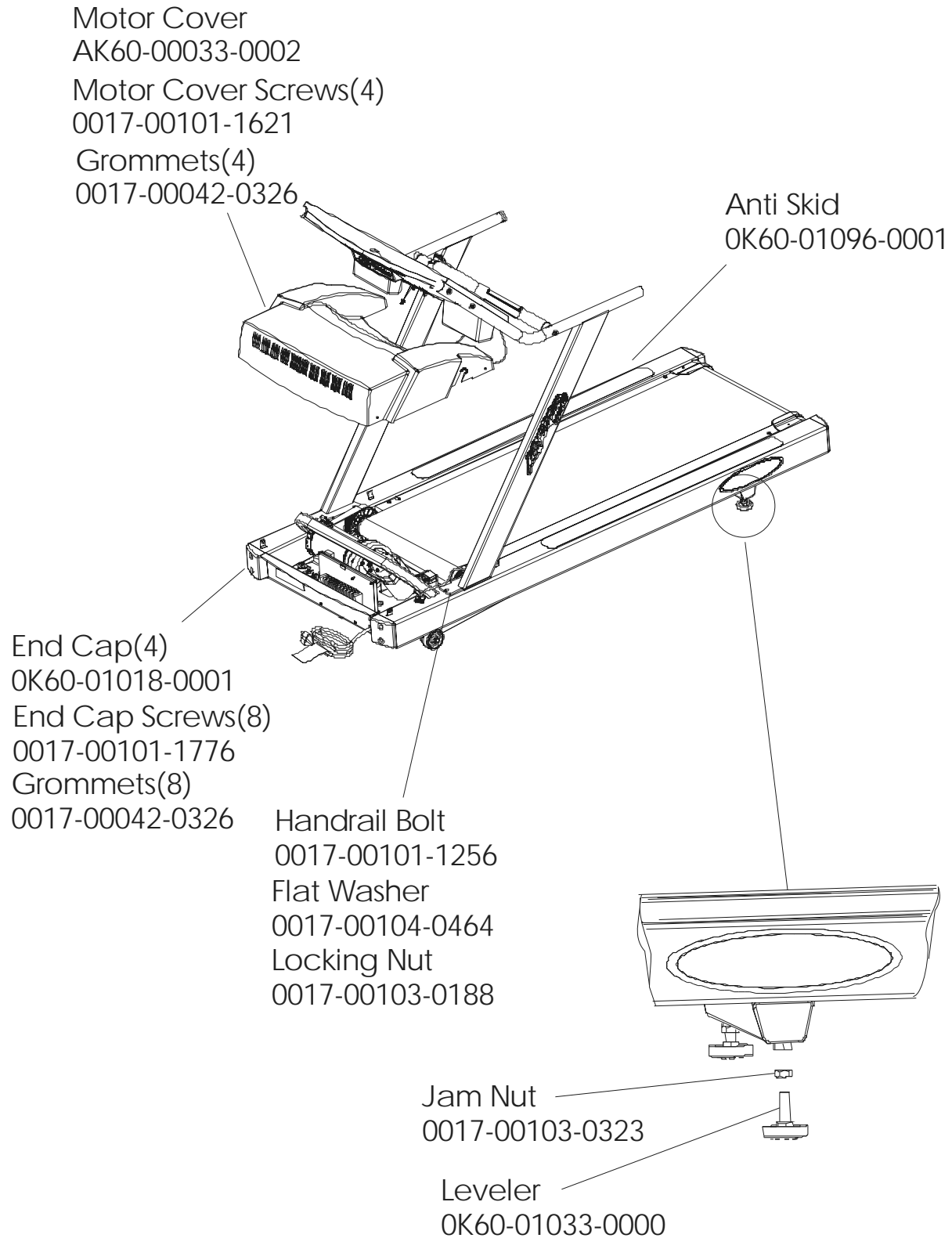

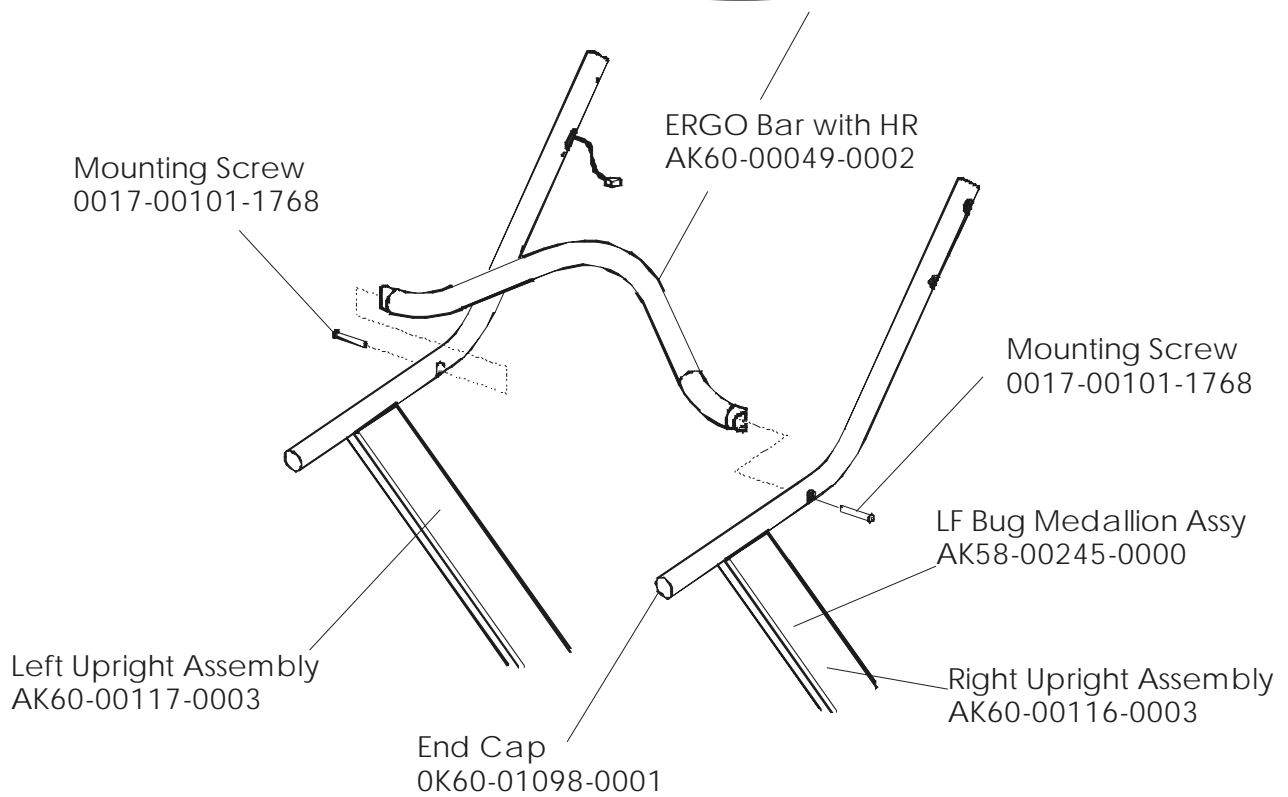
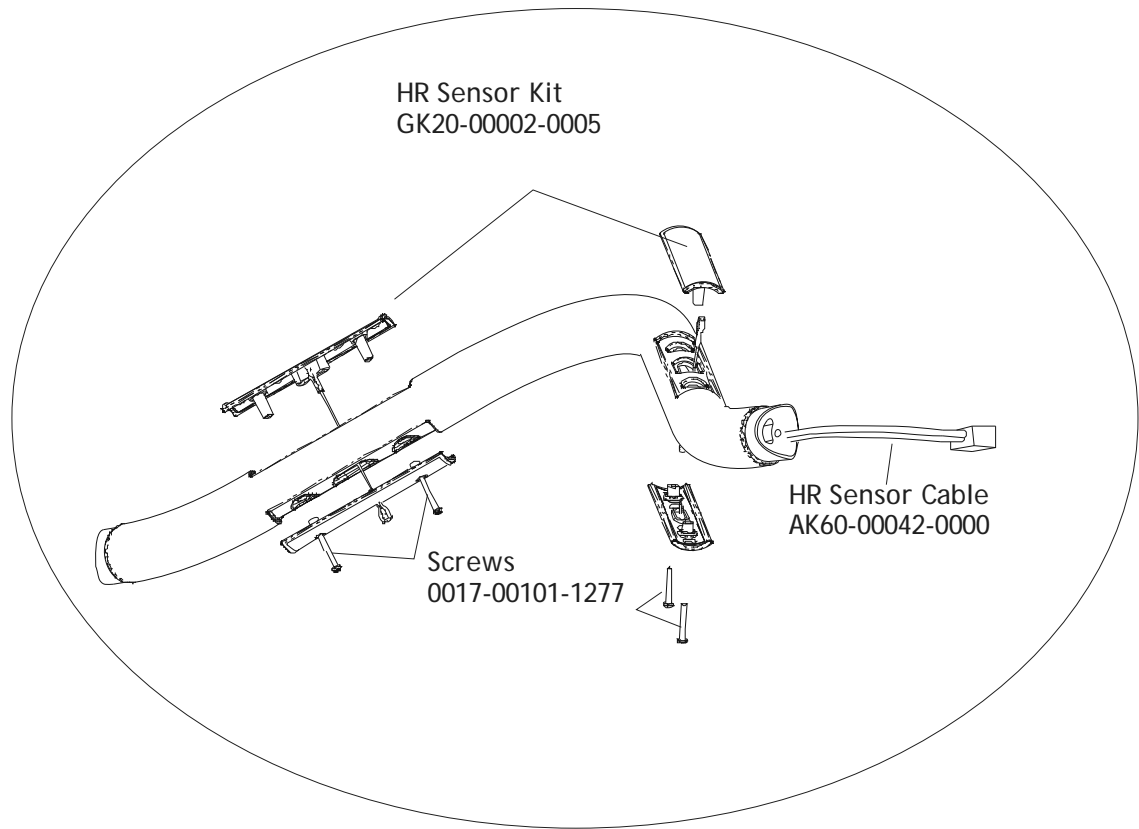

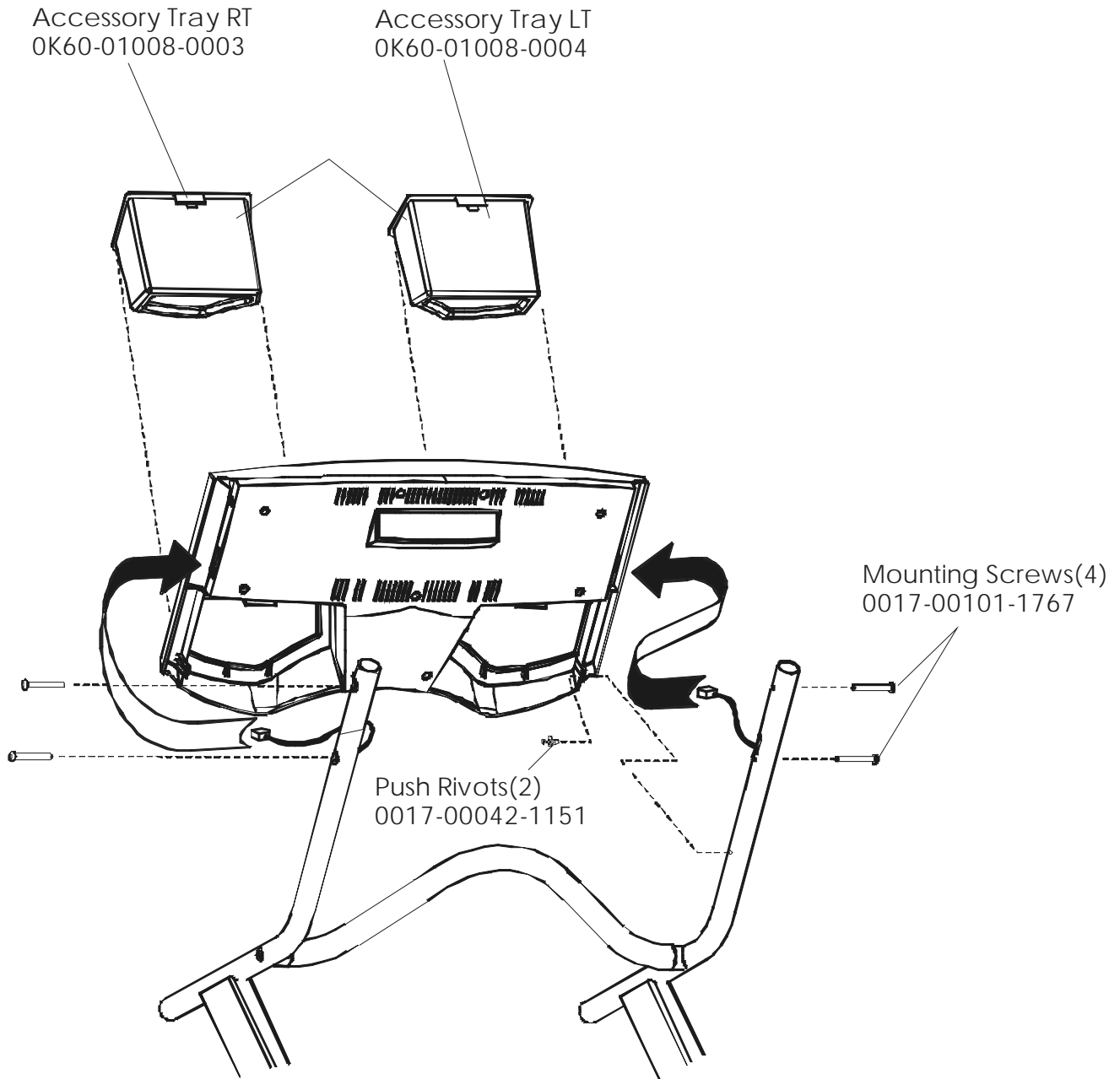

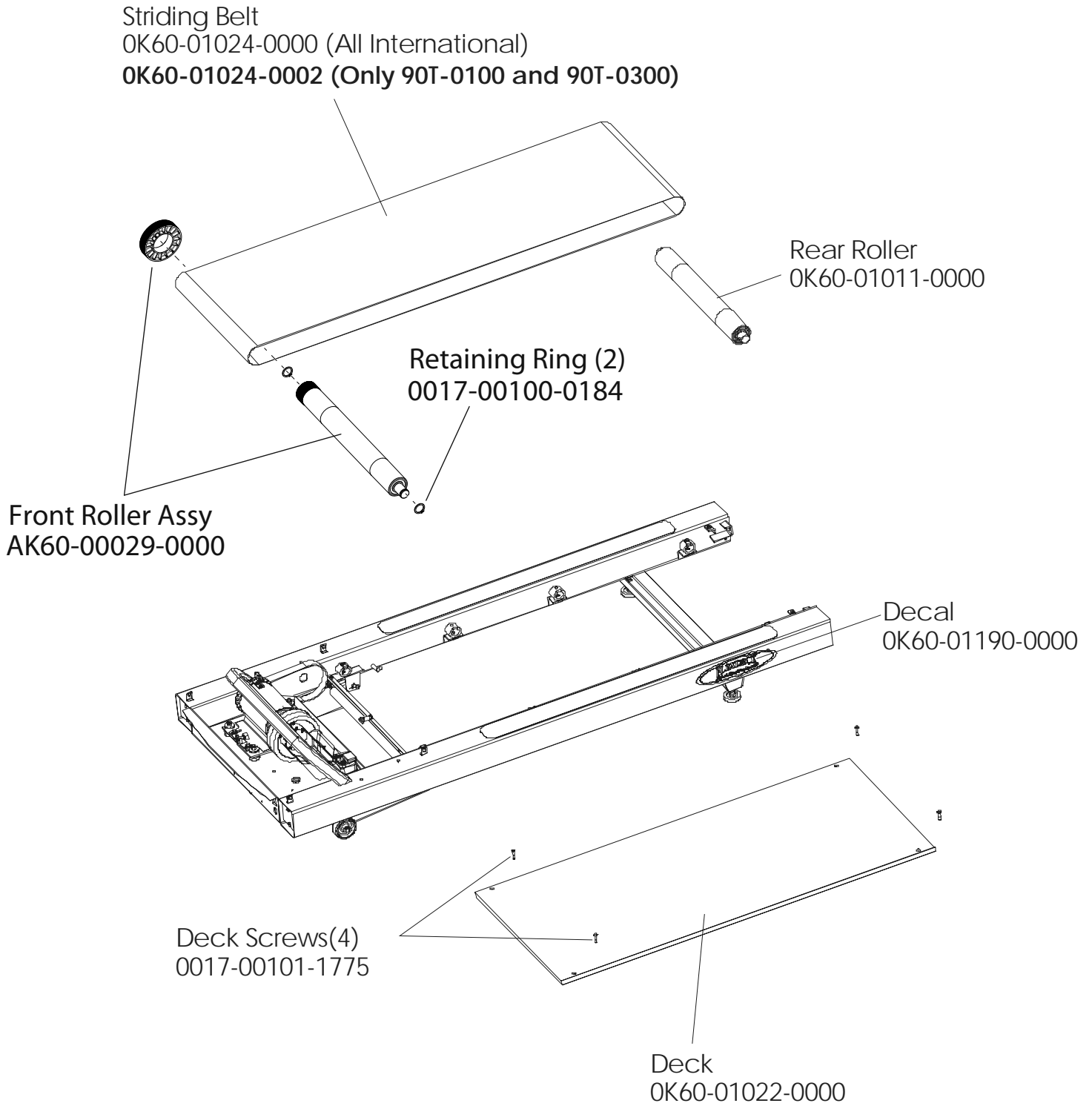

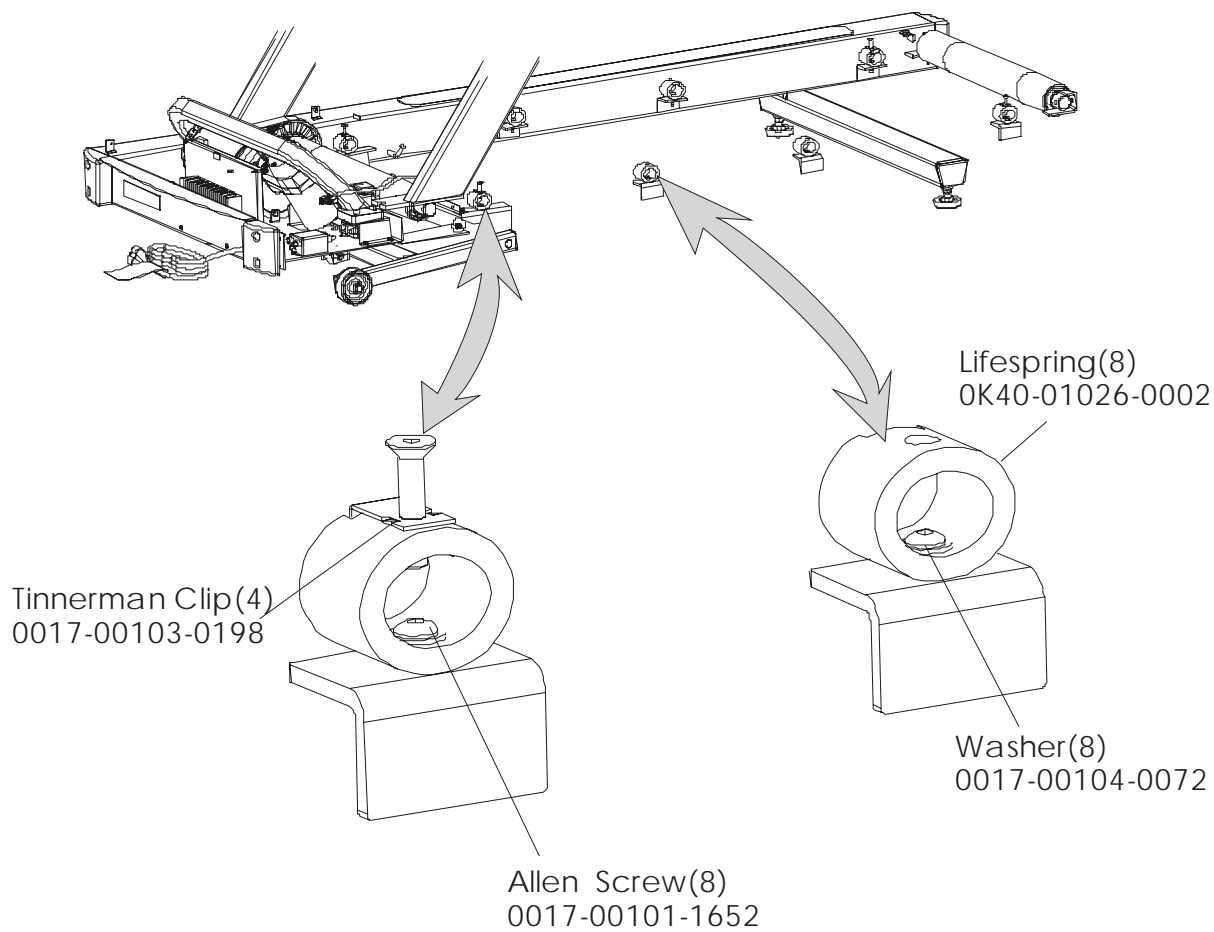
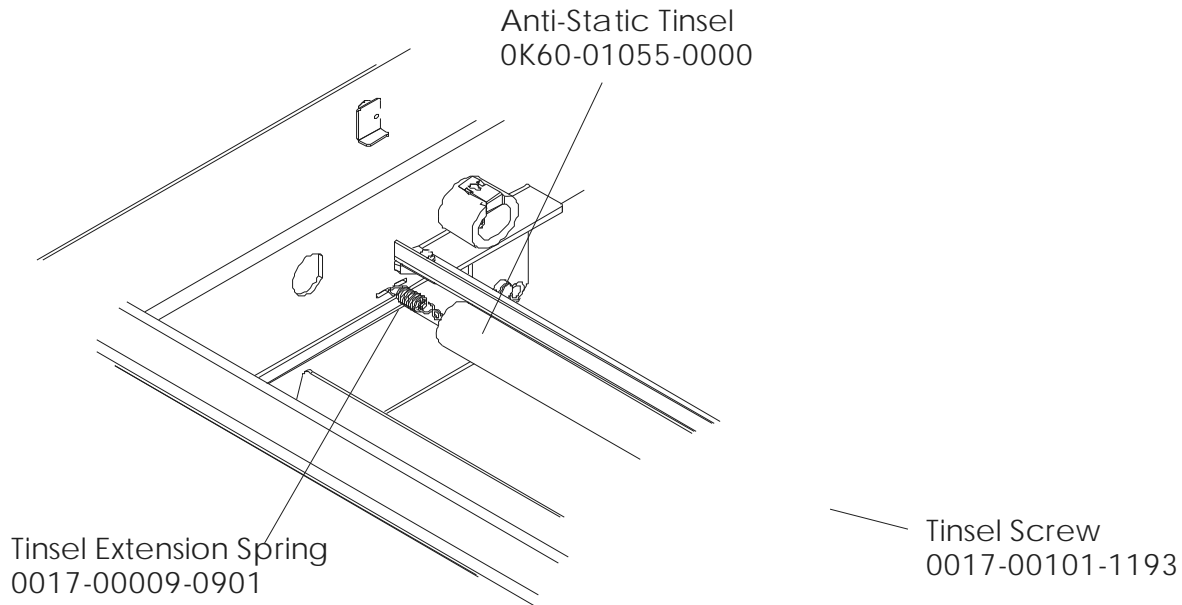

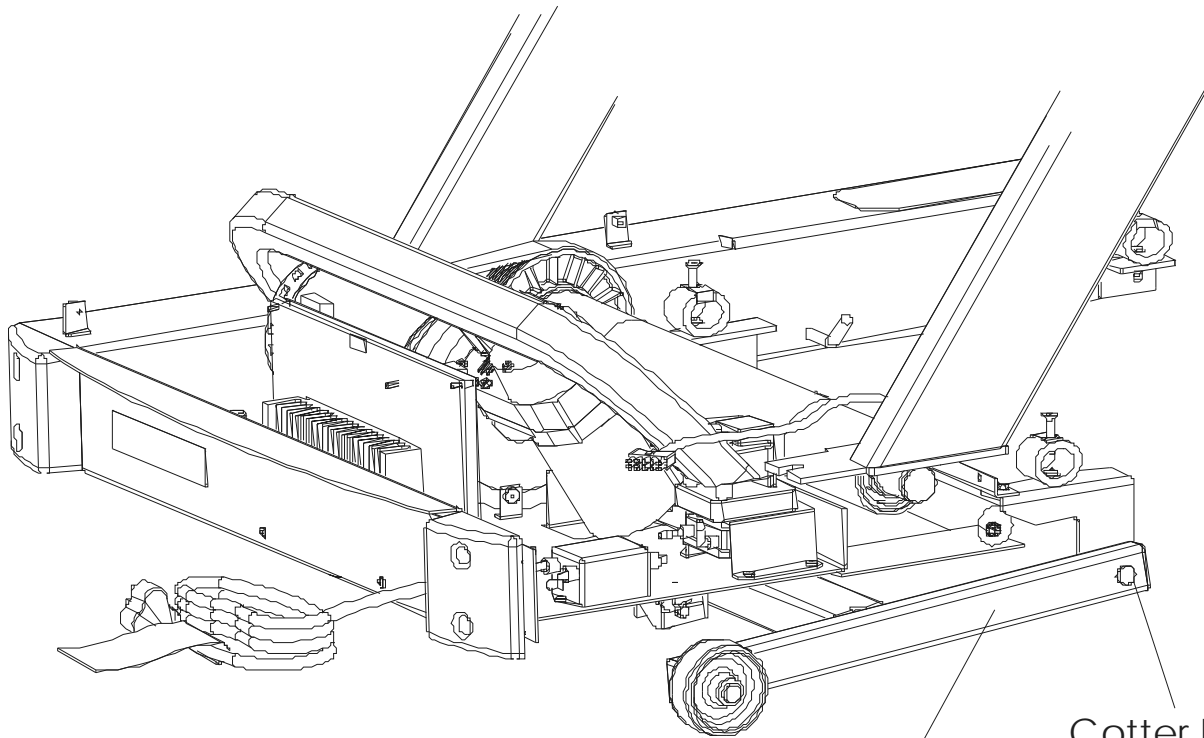

Wheel Assembly
OK60-01020-0000
Cap
OK60-01092-0000
Cotter Pin
0017-00007-0208
Clevis Pin
0017-00007-0271

Lift Frame Assembly
AK60-00065-0000

Cotter Pin
0017-00007-0208
Clevis Pin
0017-00007-0270

Lift Motor
OK60-01094-0000 (120v)
OK60-01166-0000(220v/60Hz)

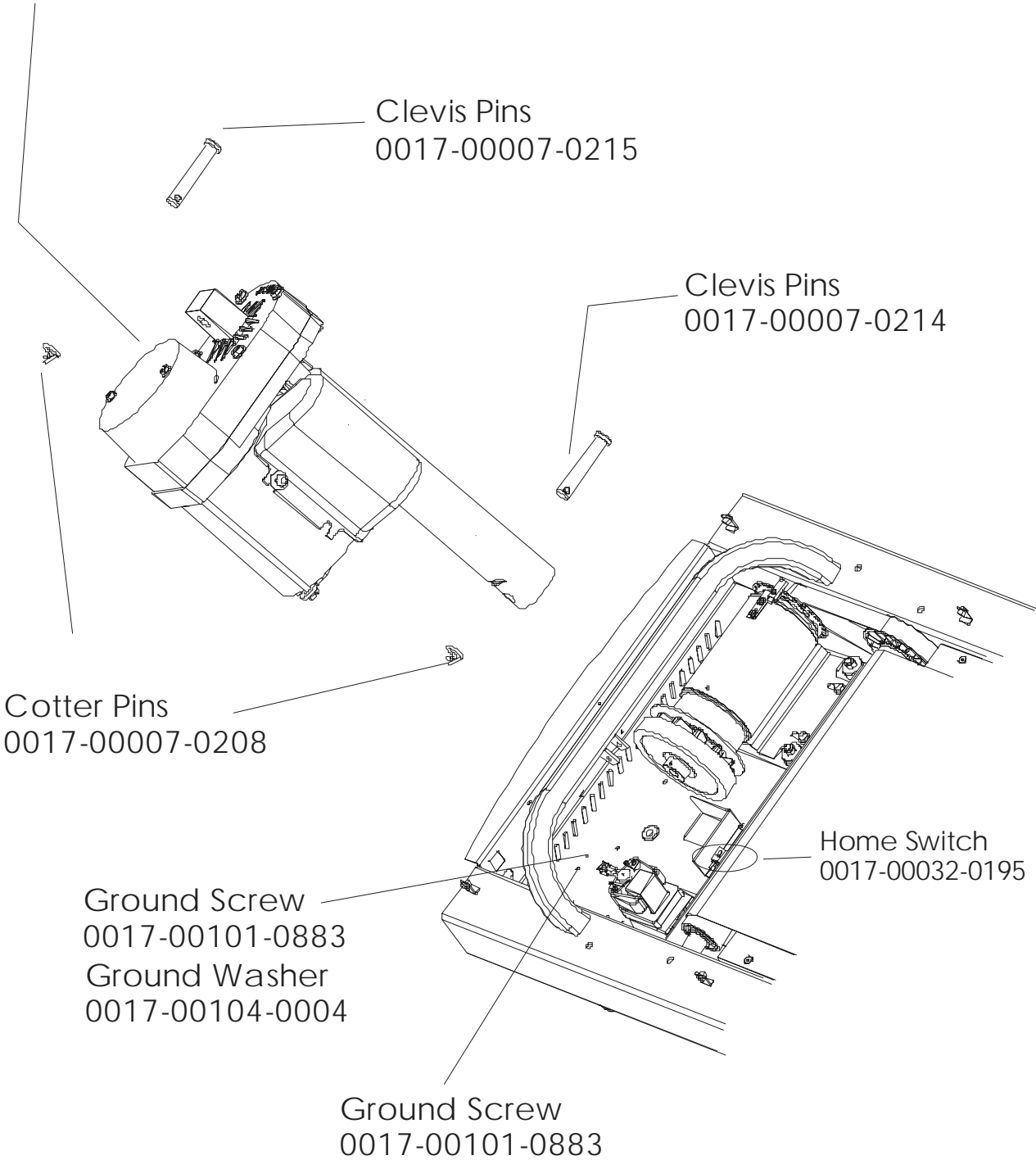

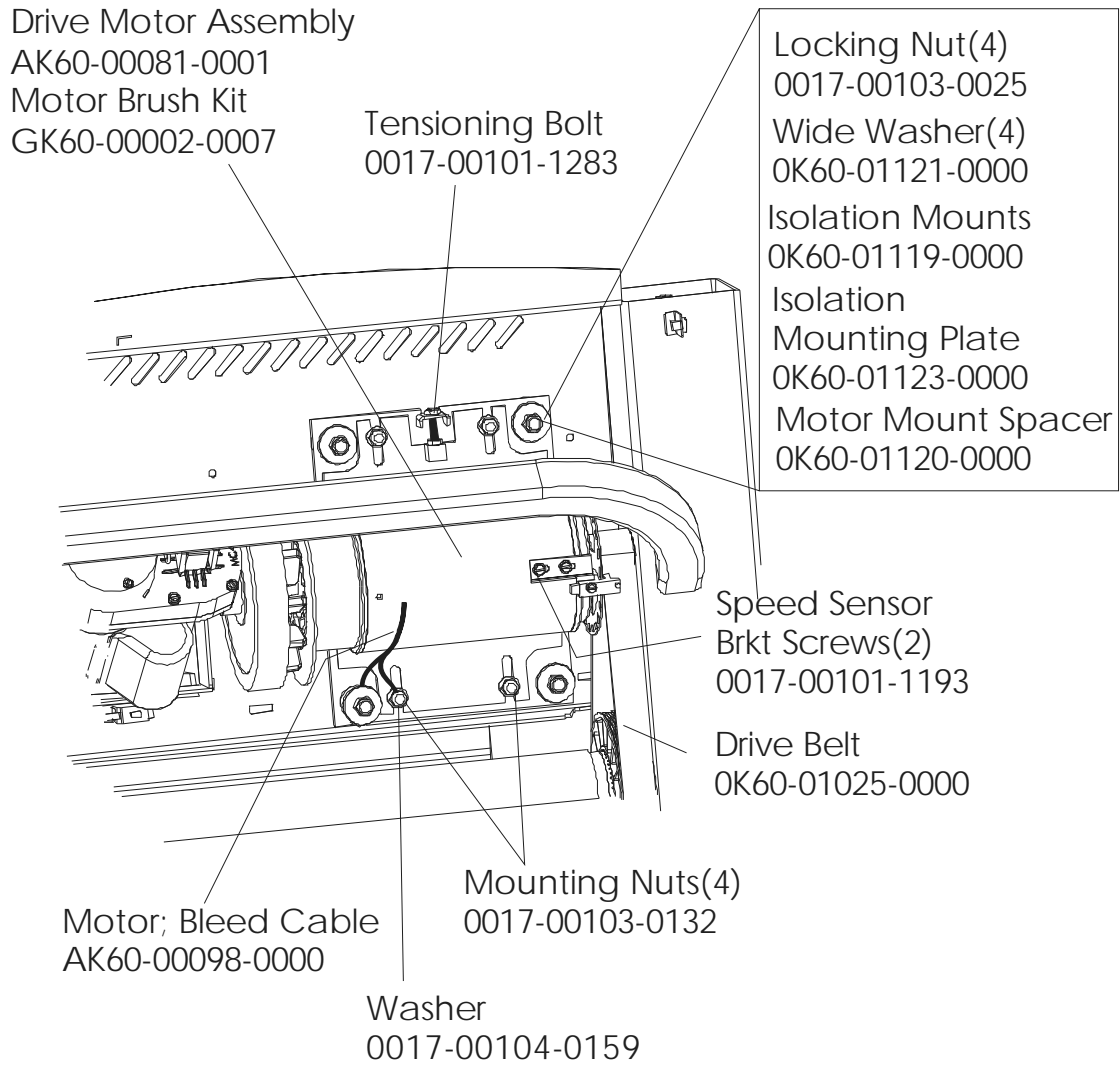

Not applicable for models 90T-0100 or 90T-0300

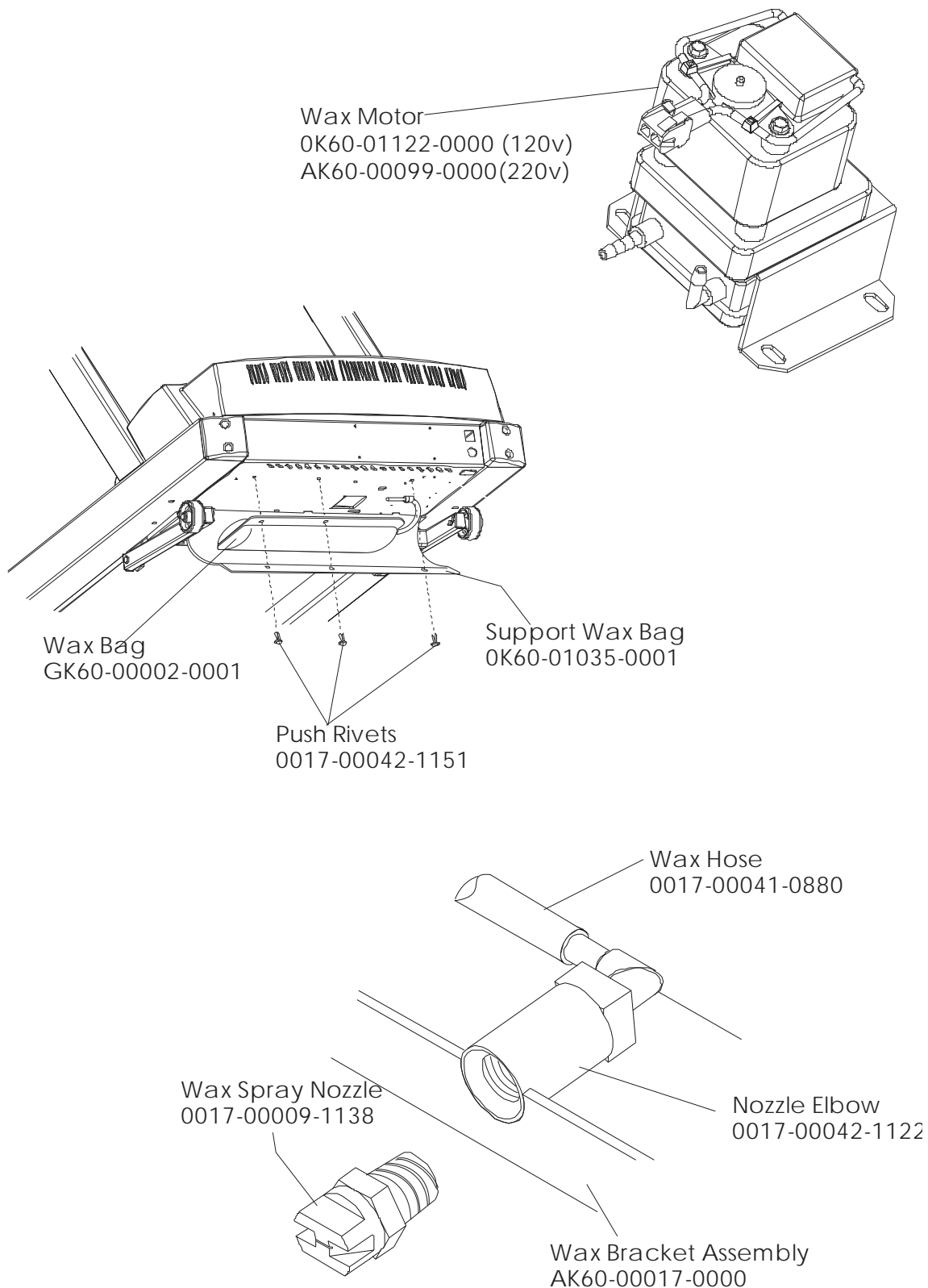

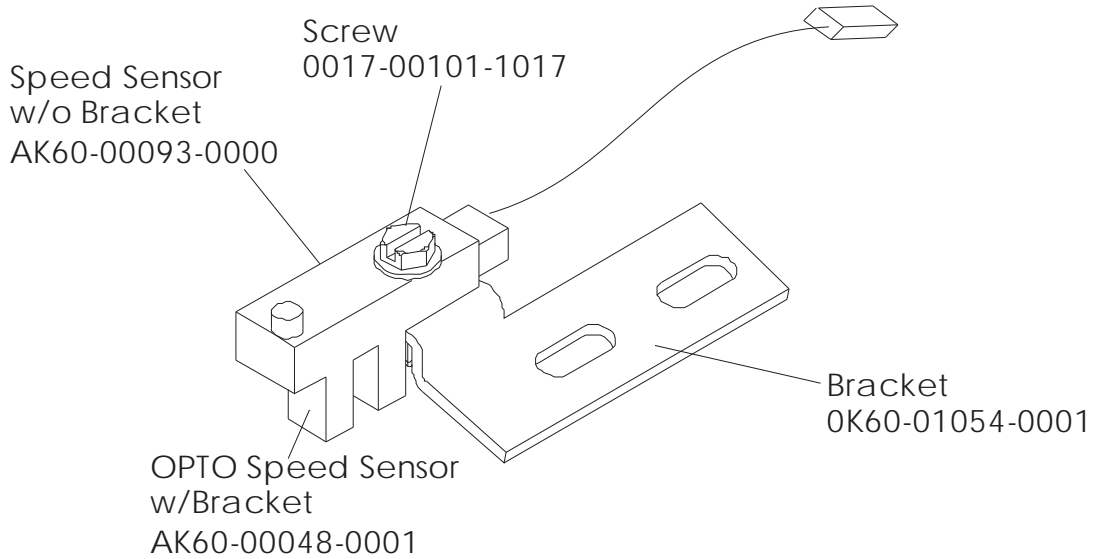
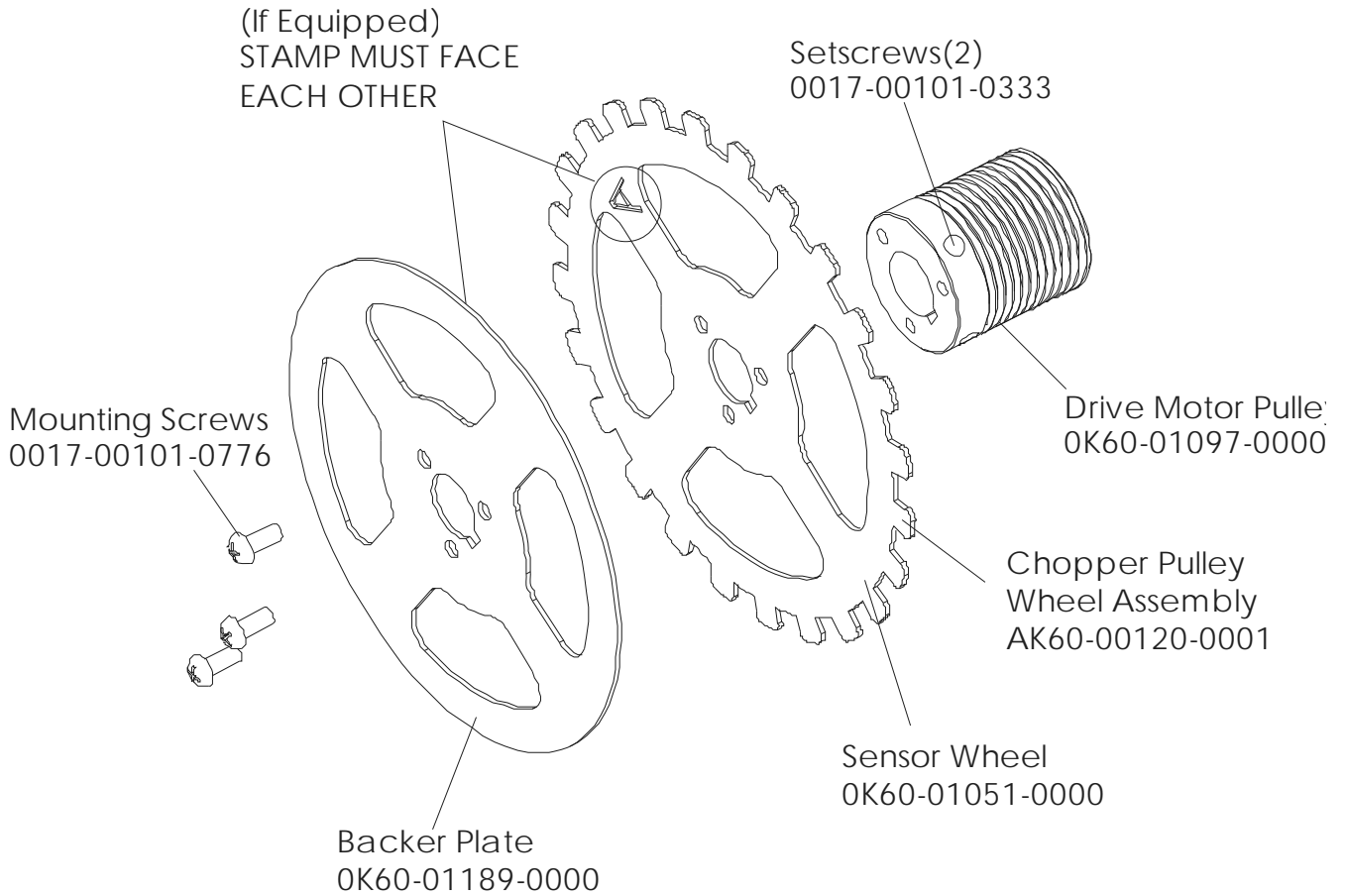

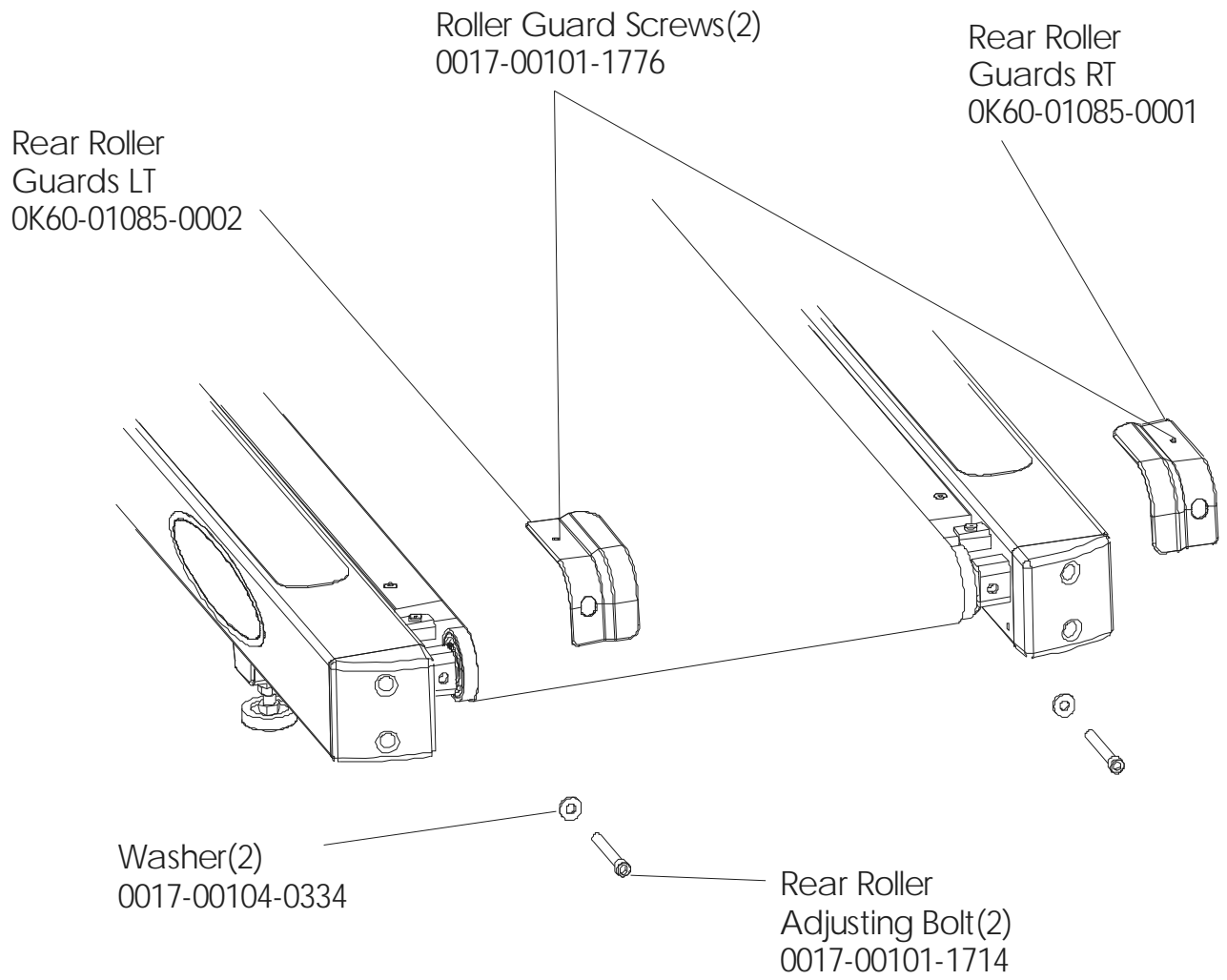

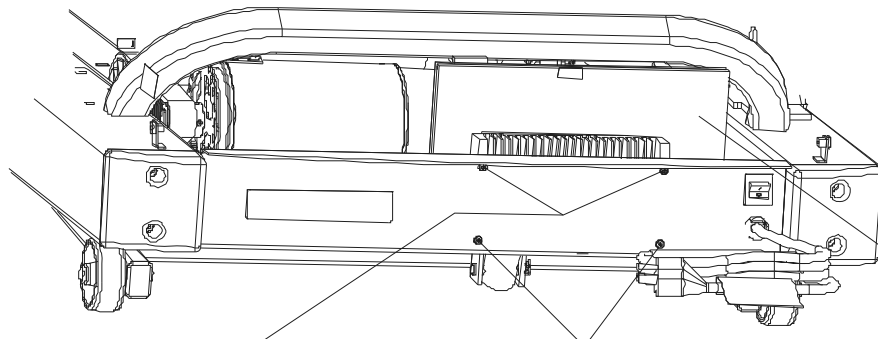

DC Controller Top
Mounting Screws(2)
0017-00101-0168
Lock Washers(2)
0017-00104-0460

DC Controller Bottom
Mounting Screws(2)
0017-00101-0162

DC Controller
GK60-00002-0002
100-120 Volts/50-60 Hz
GK60-00002-0003
200+ Volts/50-60 Hz

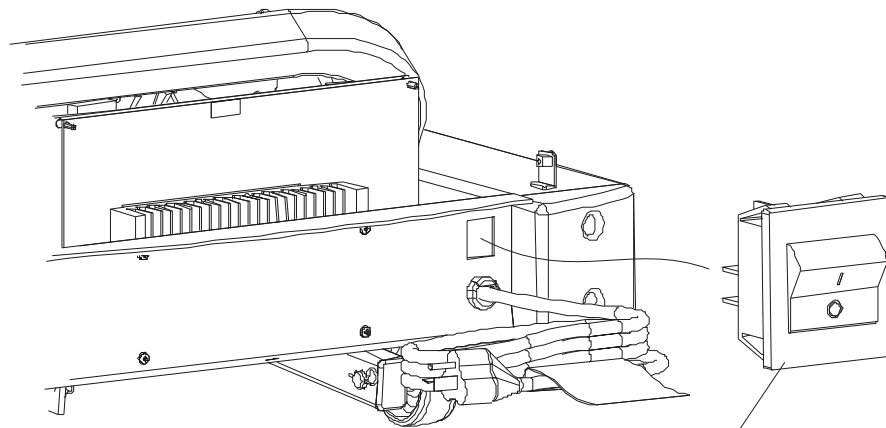

ON/OFF Switch
0017-00032-0198

